

承认书

SPECIFICATIONS FOR APPROVAL

客户/CUSTOMER: _____

产品描述/DESCRIPTION: POWER 31.5W

OUTPUT 30-35V900mA

产品型号/OUR MODEL NO. : JPQL-350090

样品编号/SAMPLE No. : JPQL350090

日期/DATE: 2010-07-21

APPROVED BY (批准)	NOTE (备注)
CUSTOMER SIGNATURE(S)	

ISSUED BY _____
(拟制)

CHECKED BY _____
(审核)

APPROVED BY _____
(批准)

WaterProof Electronic LED Driver
(LED防水驱动电源)

版本目录/Rev. List

版本/Rev	日期/Date	描述/Description	制订/Design
A0	2008-07-10	新版本/New Rev.	Xian

Table of contents

1. 描述/DESCRIPTION.....	3
2. 输入特性/INPUT CHARACTERISTICS.....	3
3. 输出特性/OUTPUT CHARACTERISTICS.....	4-5
4. 保护功能/PROTECTION FUNCTION.....	5
5. 环境要求/ENVIRINMENTAL REQUIREMET.....	5-6
6. 安全及EMI要求/SAFETY AND EMC REQUIREMENT.....	6
7. 结构参数/MECHANICAL REQUIREMENT.....	7
8. 线材/CORD.....	8

型号/Our model; JPQL-350090

日期/Date:2010-07-21

客户/Customer:

样品编号/SAMPLE No;JPQL350090

1. 描述/SCOPE:

本规格书适应于JPQL-350090型号的开关电源.

The purpose of the document is to specify the functional requirements of a 31.5W switching power supply.

2. 输入特性/INPUT SHARACTERISTICS:

2.1 输入电压/Input Voltage;

额定电压/Rated Voltage: 100-240Vac

调整范围 Variation /Range: 90-264Vac

2.2 输入频率/Input Frequency:

额定频率/Reted Frequency; 50/60Hz

调整频率/Variation Frequency: 47-63Hz

2.3 输入电流/Input Current:

当输入交流电压为额定值的下限电压负载满载时, 最大输入交流电流04A

0.4Amps max At any input voltage and rated, DC output rated load

2.4 浪涌电流/Input Current:

当输出为额定负载, 环境温度为25℃, 输入240Vac 冷态 起机时的最大浪涌电流小于为40A.

40Amps MAX, cold start at240vac input , with rated load and 25^oC ambient.

2.5 AC漏电流/Ac Leakage Current:

当输入电压240VAC时, 最大漏电流为0.25mA.

0.25mA Max At240Vac input

WaterProof Electronic LED Driver
(LED防水驱动电源)

型号/Our model; JPQL-350090

日期/Date: 2010-07-21

客户/Customer:

样品编号/SAMPLE No; JPQL350090

3. 输出特性/OUTPUT CHARACTERISTICS:

3.1 输出功率/Power output

电压 Voltage	最小负载 Min Load	额定负载 Rated. Load	峰值功率 Peak	输出功率 Output power
30-35VDC	0.01A	900mA (恒流)		7W

3.2 负载特性, 调整率/Combined Load/Line Regulation

电压 Voltage	最小负载 Min Load	额定负载 Rated. Load	电压范围 Voltage Range	线性调整 Line Regulation
30-35VDC	0.01A	900mA (恒流)	5%	±1%

3.3 纹波和噪音 Ripple and Noise:

测试条件:在额定电压及额定条件下,使用示波器带宽为20MHz连接到充电器的输出端,同时输出端并联一个47UF的电解电容和一个0.1UF的瓷片电容.

Under minimal voltage and nominal load, the ripple and noise are as follow when measure with Max, Bandwidth of 20MHz and parallel 47uf/0.1uf, crossed conected at testing point

电压/ Voltage 最大纹波/最大噪音/ Ripple and Noise (Max)
+10Vdc ≤1% mVP-P

3.4 启动延迟时间/ Turn on delay time:

当输入115Vac和输出最大负载时,最大启动时间为2S
2second Max, at 115Vac input and output Max, load

3.5 上升时间/ Rise time:

当输入115Vac和输出最大负载时早大时间为40MS
40 Ms Max, at 115vac input and output Max, load

WaterProof Electronic LED Driver
(LED防水驱动电源)

型号/Our model; JPQL-350090

日期/Date: 2010-07-21

客户/Customer:

样品编号/SAMPLE No; JPQL350090

3. 6保持时间/ Hold up time:

当输入115Vac和输出最大负载时,最小保持时间为5mS

5ms Max, at 115Vac input and output Max, load

3. 7效率/Efficiency:

当输入115Vac和输出最大负载时,最小75%

75% Min at 100Vac input and output Max, Load

当输入240Vac和输出最大负载时,最小80%

80% Min at 240Vac input and output Max, Load

3. 8过冲/Overshoot:

在电源开启或关闭的时候,最大15%.

15% Max, When power supply at turn or turn off.

4. 保护功能/ Protetion function:

4. 1短路电路保护/ Short circuit protection:

该电源供给器在短路解除时能正常工作恢复

The power supply will be auto recoverde when short circuit faults remove

4. 2过流保护/Over current Protection:

过流故障排除后,电源将自动恢复正常工作.

The power supply will be autorecovered when over current faults remove.

4. 3过压保护/Over voltage protection:

当输出电压超过额定电压的150%-180%时,电源将保护,故障排除后能恢复正常工作.

The power supply will auto recovered when faults remove 150%-180%

WaterProof Electronic LED Driver
(LED防水驱动电源)

型号/Our model; JPQL-350090

日期/Date: 2010-07-21

客户/Customer:

样品编号/SAMPLE No; JPQL350090

5. 环境要求/ENVIRONMENTAL REQUIREMET:

5. 1工作温度/Operating temperature:

0°C-40°C,满载, 正常工作

0°Cto40°C, Full toad normal operation.

5. 2储藏温度/Storage temperature: -20°Cto80°C

带外壳/with package

5. 3工作湿度/Relative Humidity

5% (0°C)-90% (40°C), 72小时, 满载, 正常工作

5% (0°C)-90% (40°C)RH, 72Hrs, Full toad, Normal operating.

5. 4振动/Vibration:

1. 测试标准:国家电工电子委员会

Operating: IEC 721-3-3 3M3

5-9Hz, A=1.5mm

加速度(9-200Hz, Acceleration 5m/S²)

5. 5运输/Transportation:

IEC 721-3-2 2M2

5-9Hz A=3.5mm

5. 6轴向振动/Axes cycles per axis

在测试过程中不能出现永久性的损坏

No permanent damage may occur during testing

5. 7跌落试验/Dropping Packed:

一个角, 三个棱, 六个面

1corner 3edges and 6 surfaces

高度 50cm/Height: 50cm

WaterProof Electronic LED Driver
(LED防水驱动电源)

型号/Our model; JPQL-350090

日期/Date: 2010-07-21

客户/Customer:

样品编号/SAMPLE No; JPQL350090

6. 安全及EMI要求/SAFETY AND EMI REQUIREMENT:

6. 1高压/DIELECTRIC STRENGTH HI-POT:

初级对次级/Primary to secondary; 1800VDC/5mA/60S for type test

6. 2绝缘抗阻/Insulation resistance:

初级对次级/Primary to secondary: 10MΩ min at 500VDC

6. 3 防护等级: Ip67 // Protection Rank: Ip67 //

6. 4 EMI标准/EMI Standard: (可选项)

电源的电磁兼容符合下列标准/ The power supply shall compliance with the following Criterion:

1) 传导骚扰/Conduction Emission:

- * En55022 class B
- * Gb9254 class B

2) 辐射干扰/Radiated Emission:

- * En55022 class B
- * Gb9254 class B

WaterProof Electronic LED Driver
(LED防水驱动电源)

型号/Our model; JPQL-350090

日期/Date: 2010-07-21

客户/Customer:

样品编号/SAMPLE No; JPQL350090

7. 结构参数/MECHANICAL REQUIREMENT:

7.1 外壳/Enclosure:

外壳尺寸:L X W X H=140mmX38.5mmX25.5mm

The power supply size: L X W X H=140mmX38.5mmX25.5mm

■ 外形尺寸/Dimension (unit: mm)

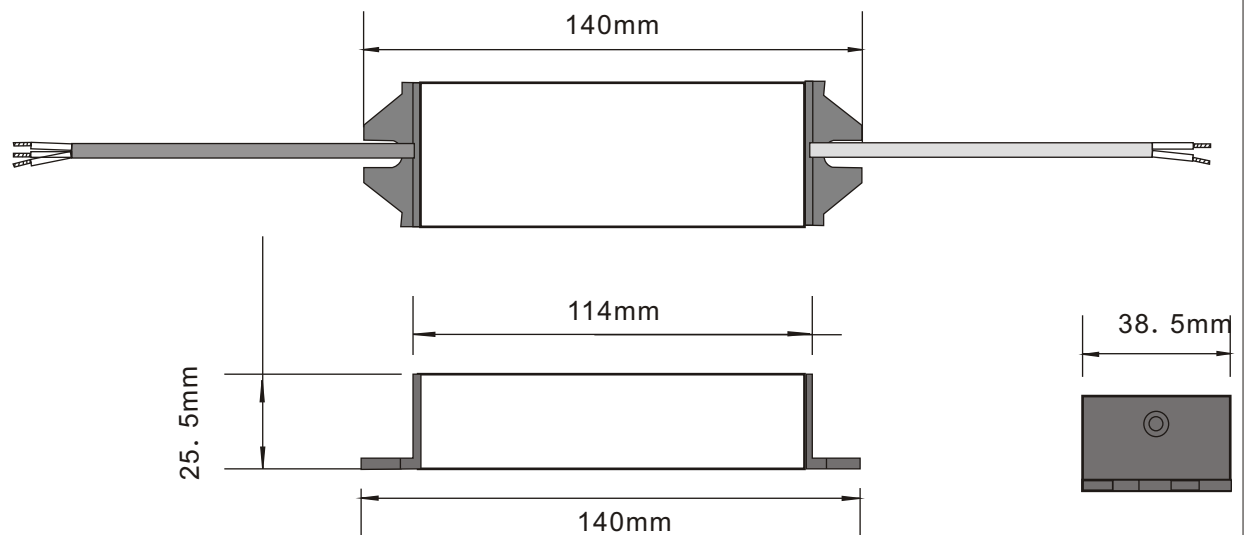

■ 安装尺寸/Localization

